

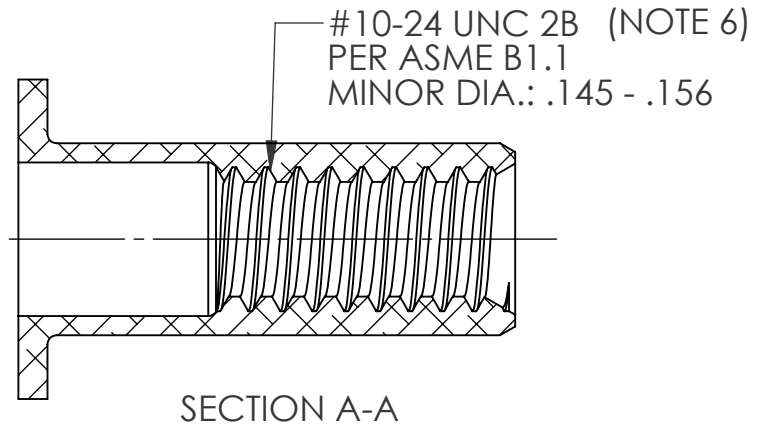

REVISIONS			
REV.	DESCRIPTION	DATE	ECN
A	INITIAL RELEASE	5/7/09	1179
B	TOLERANCE CHANGE	5/22/09	1186
C	UPDATE TO CURRENT FORMAT	6/3/10	1316

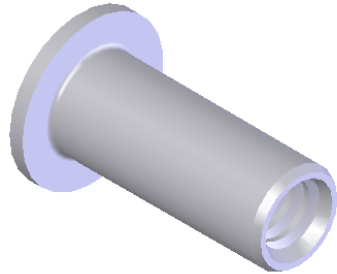
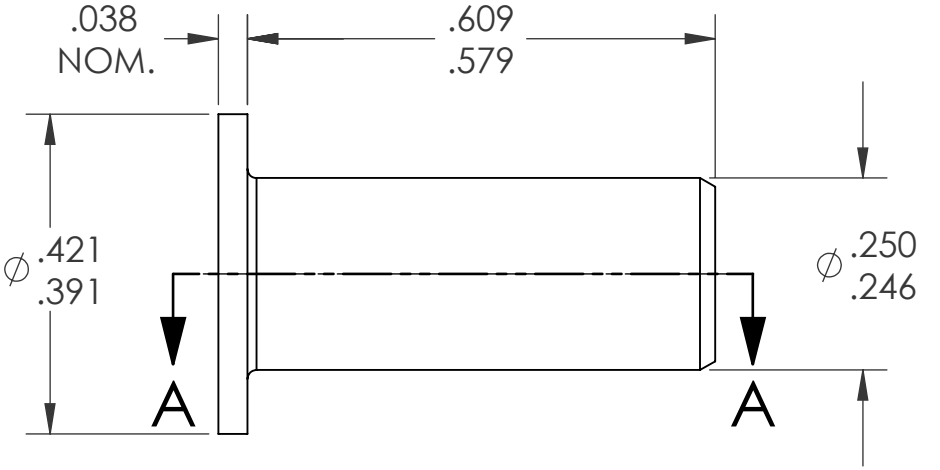
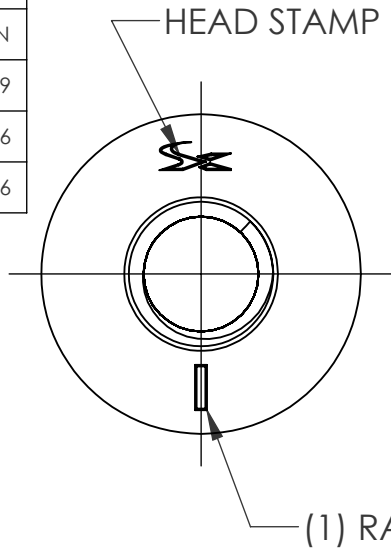

- NOTE:
- GRIP RANGE: .080 - .130
  - HOLE SIZE: .250 +.006/-.000 AFTER ALL APPLIED FINISHES.
  - INSTALLED LENGTH: .390 REF.
  - LUBRICATION: NONE
  - INSTALLATION TOOL: SPIN-PULL
  - MAY BE PRODUCED TO 3B THREAD CLASS DEPENDING ON THE MANUFACTURING LOT NUMBER OR CUSTOMER REQUIREMENT. SPECIFIC CLASS AVAILABLE UPON REQUEST.

**PROPRIETARY AND CONFIDENTIAL**  
 THIS DRAWING, AND THE INFORMATION CONTAINED HEREIN, ARE THE PROPERTY OF SHEREX AND ARE NOT TO BE USED IN ANY MANNER DETRIMENTAL TO THE INTEREST OF THE COMPANY.  
 SHEREX SOLUTIONS RESERVES THE RIGHT TO REVISE PART/DRAWING WITHOUT NOTICE.

		UNLESS OTHERWISE SPECIFIED:		NAME	DATE		
		DIMENSIONS ARE IN INCHES TOLERANCES: ANGULAR: MACH ±1 BEND ±1 TWO PLACE DECIMAL ±.01 THREE PLACE DECIMAL ±.002		DRAWN	TWR		5/7/09
		INTERPRET GEOMETRIC TOLERANCING PER: ASME Y14.5M-1994		CHECKED			
		MATERIAL A5056/A6053-T4		ENG APPR.	JVK		5/7/09
		FINISH NONE		MFG APPR.			
NEXT ASSY	USED ON			Q.A.	JVK	5/7/09	
APPLICATION		DO NOT SCALE DRAWING		COMMENTS: E-mail: info@sherex.com www.sherex.com Phone: 866-474-3739 Fax: 716-875-0358		TITLE: FLAT HEAD OPEN END	
				SIZE DWG. NO.	REV		
				<b>A</b> CA-1024A-130	C		
				SCALE: 2:1	WEIGHT: kg	SHEET 1 OF 1	